

HALF MOON TABLETOP WATER FOUNTAIN GSI-859

Review all assembly and care information before using this product. Save this manual for future reference.

Select a smooth, level surface to place the fountain. Assemble components on a soft, clean surface to avoid scratching or damaging the finish.

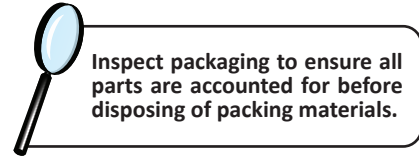
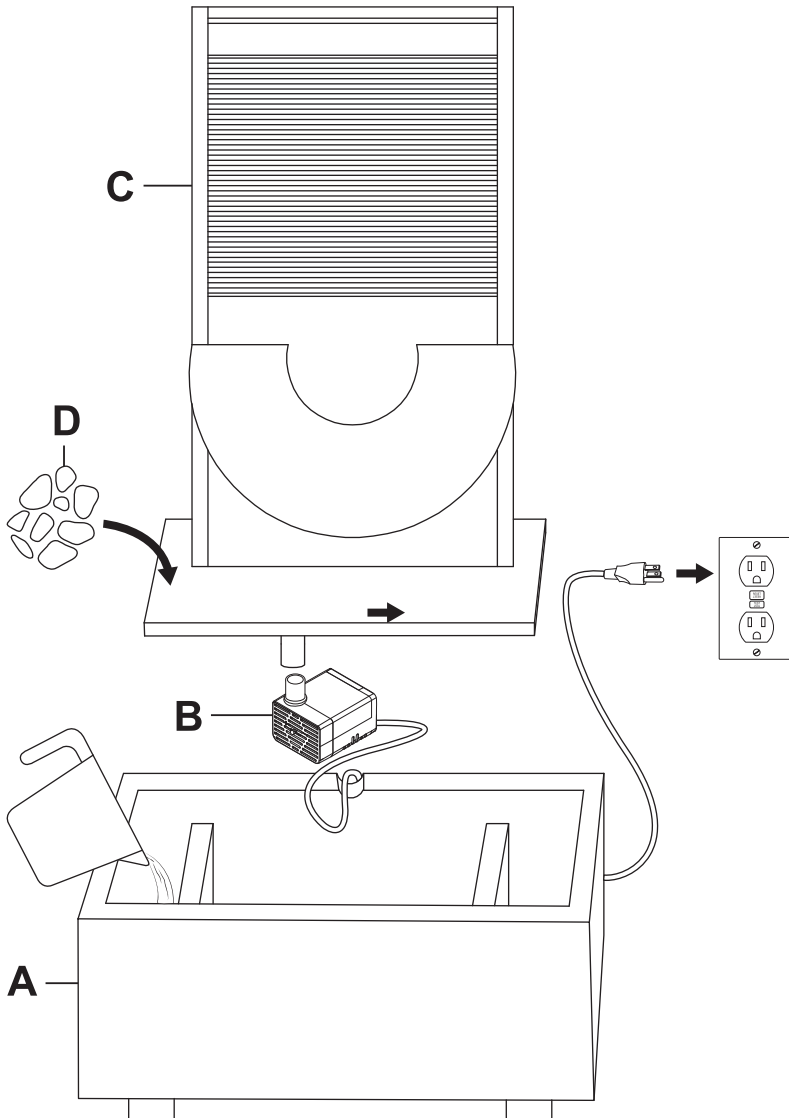

No.	PARTS	QTY.
A	Basin	1
B	Electric Submersible Pump	1
C	Fountain Body	1
D	Decorative Stones	1 PK

IMPORTANT NOTES:

Use care when unpacking and assembling this fountain. Check the basin for leaks before assembling the fountain. The sealant used to join the resin pieces can become cracked if the fountain is not handled with care. Simply add water and wait to see if water begins to leak. If a leak is discovered, contact an expert at your local hardware store for an appropriate sealant and carefully follow sealant manufacturer's instructions to seal the leak.

The water tubing is built into the fountain body. Take care when handling the water tube; detaching the water tube from the fountain body will damage the fountain and void the product warranty.

WARNING: THE ONE-YEAR WARRANTY DOES NOT COVER DAMAGES OR DEFECTS CAUSED BY THE APPLICATION OF CHEMICAL TREATMENTS, PROTECTIVE COATINGS, OR SEALANTS.

ASSEMBLY

1. Connect Pump (B) to the water tube on Fountain Body (C).
2. Ensuring the pump power cord runs over the groove on the back of the basin, place the fountain body onto Basin (A).
3. Rinse Decorative Stones (D) with clean water. Gently arrange stones on the bottom of the fountain body.
4. Fill the fountain with enough water to keep the pump fully submerged during operation.
5. Plug the power cord into a properly grounded GFCI outlet.

NOTE: When first plugged in, there may be air trapped in the pump. It may take several moments for trapped air to escape, allowing water to flow.

Care & Maintenance

- For indoor use only.
- Check the water level frequently to ensure the pump remains fully submerged; never allow the pump to run dry as it will burn out the motor.
- Only use water in this fountain. Distilled water will help prevent mineral buildup but is not required. Avoid heavily chlorinated water as it may damage the fountain and pump.
- Periodically change the water to reduce scale and buildup — clean components regularly for optimal performance and appearance. DO NOT use abrasive materials and harmful additives such as bleach or chlorine to clean the fountain or pump.
- Always unplug the fountain before cleaning and/or maintaining the fountain and the recirculating pump.
- Take care when handling the pump; only pick it up by the body of the pump, never by the power cord.
- Although this fountain was designed for indoor use, there is potential for splashing or slow leaks. Test the fountain on a water-safe surface. Always protect surfaces that can be damaged by water.

Troubleshooting

- If water is not flowing within several moments of the fountain being plugged in, ensure that the pump is fully submerged underwater. Add water to the reservoir if necessary. The pump may have air bubbles in the filter, which can prevent water from circulating properly and can also cause excess pump noise. Unplug the power supply for a few moments and plug it back in.
- Check the flow control on the body of the pump, it may need to be adjusted to achieve the desired water flow rate.
- Inspect the pump and tubing for obstructions.
- Pump noise can be caused by trapped air, low water level, or the pump being too close to the walls of the fountain. While the pump is fully submerged, try gently tapping the pump with your finger to help release the trapped air. Also, check if adding water or moving the pump helps to reduce noise.
- Make sure the AC adapter is fully connected to the pump power cable. If the light is not working, ensure the cable is fully connected, and the seal is adequately tightened (do not over-tighten).
- Make sure the power outlet is working; consult a certified electrician if in doubt about electrical connections.

If you experience issues with assembly, pump operation, or the product was damaged during shipping, please contact our customer service team through one of the methods mentioned at the top of page 1.

Please have the item number and order information ready to expedite response time.

IMPORTANT SAFETY INFORMATION

- Keep fountain out of reach of children and pets.
- Fountains may splash or leak; always protect surfaces that can be damaged by water.
- Prevent water loss or damage to electrical sockets by ensuring the power cord has a drip loop; a diagram of a drip loop is shown on the right.
- Make sure the power cord is away from traffic areas.
- Keep power cord away from all heat sources. Do not use electrical cords in areas with high temperatures.
- Check the water level frequently to ensure the pump remains fully submerged; never allow the pump to run dry as it will burn out the motor.
- Always unplug the power supply before cleaning and maintaining the fountain and the recirculating pump.
- Take care when handling the pump; only pick it up by the body of the pump, never by the power cord.

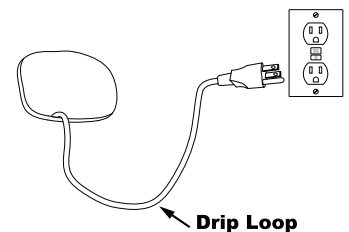

Drawing is for visual reference only, cord placement and plug type vary by fountain style.

Any modification to the product or failure to follow recommended care will void the product warranty.

WARNING!

Manufacturer and seller expressly disclaim any and all liability from personal injury, property damage or loss, whether direct or indirect, or incidental, resulting from the incorrect attachment, improper use, inadequate maintenance, or neglect of this product.